

### Metric Female Test Couplings

PART NO.	TUBE OD	SERIES	THREAD G	HEX	H	H 1	FIG	BAR/PSI
20.50.06	6	L	M12x1.5	0.55	1.60	2.60	1	250/3600
20.51.06	6	H	M14x1.5	0.67	1.60	2.60	1	630/9100
20.50.08	8	L	M14x1.5	0.67	1.60	2.20	2	250/3600
20.51.08	8	H	M16x1.5	0.75	1.60	2.20	2	630/9100
20.50.10	10	L	M16x1.5	0.75	1.60	2.20	2	250/3600
20.51.10	10	H	M18x1.5	0.87	1.60	2.20	2	630/9100
20.50.12	12	L	M18x1.5	0.87	1.60	2.10	2	250/3600
20.51.12	12	H	M20x1.5	0.94	1.60	2.10	2	630/9100
20.51.14	14	H	M22x1.5	1.06	1.60	2.40	2	630/9100
20.50.15	15	L	M22x1.5	1.06	1.60	2.30	2	250/3600
20.51.16	16	H	M24x1.5	1.18	1.60	2.80	2	400/5800
20.50.18	18	L	M26x1.5	1.26	1.60	2.80	2	160/2300
20.51.20	20	H	M30x2	1.42	1.60	3.00	2	400/5800
20.50.22	22	L	M30x2	1.42	1.60	3.00	2	160/2300
20.51.25	25	H	M36x2	1.81	1.60	2.60	2	400/5800
20.50.28	28	L	M36x2	1.61	1.60	2.60	2	100/1450
20.51.30	30	H	M42x2	1.97	1.60	2.80	2	250/3600
20.50.35	35	L	M45x2	1.97	1.60	2.80	2	100/1450
20.51.38	38	H	M52x2	2.36	1.60	2.90	2	250/3600
20.50.42	42	L	M52x2	2.36	1.60	2.80	2	100/1450

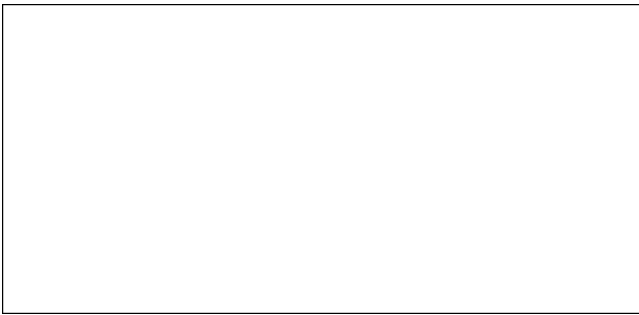

### Test Kit

- The test kit can be made individually on customer's request.
- Case Material is durable plastic (black), inlays are foam.
- Dimensions of case: L x W x H = 11.8" x 13.9" x 3.15"
- A maximum of three pressure gauges can be stored.

- EXAMPLE:**
- Pressure Gauges  
1 x 1,000 PSI, 1 x 6,000 PSI, 1 x 10,000 PSI
  - Gauge Adaptor  
1 x 20.20.43
  - Direct Gauge Adaptor  
1 x 20.21.43
  - Hose Connection  
1 x 20.22.22
  - Test Points  
1 x 20.10.67; 1 x 20.10.59; 1 x 20.10.60
  - Hose Assemblies  
1 x 20.30.72"

38

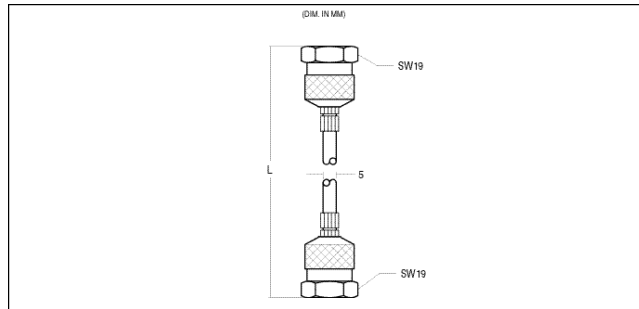

### Metric Microbore Hose Assemblies

PART NO.	END	END
20.30.XX	Both M16 x 2	
10.30.XX	Both M16 x 1.5	
30.30.XX	Both M12 x 1.5	
50.43.XX	M16 x 2	M16 x 1.5
50.44.XX	M16 x 1.5	M12 x 1.5
50.45.XX	M16 x 2	M12 x 1.5

Notes:  
 XX = Length e.g. 1,000 mm = NN.NN.10  
 10 ft. = NN.NN.120"  
 Standard Lengths: 200, 400, 600, 800, 1,000, 2,000, mm etc.  
 Microbore hose is also available with 4mm (.157") ID.

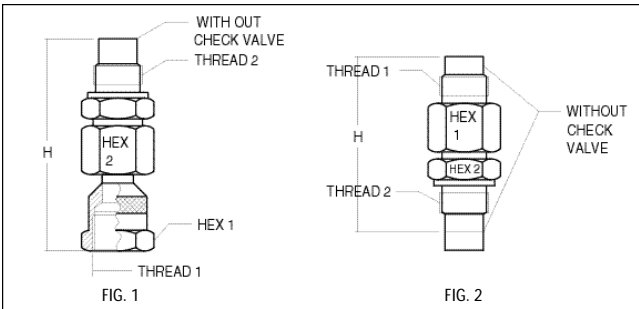

### Bulkhead Micro-Test Couplings

PART NO.	THREAD 1	THREAD 2	HEX 1	HEX 2	H	FIGURE
20.24.24	M16 x 2	M16 x 1.5	0.75	0.67	2.20	1
20.24.22	M16 x 2	M16 x 2	0.75	0.67	2.20	1
20.24.25	M16 x 1.5	M16 x 2	0.75	0.67	2.20	1
20.24.26	M16 x 1.5	M16 x 1.5	0.75	0.67	2.20	1
20.22.22	M16 x 2	M16 x 2	0.67	0.67	2.40	2
20.22.24	M16 x 2	M16 x 1.5	0.67	0.67	2.40	2
20.22.26	M16 x 1.5	M16 x 1.5	0.67	0.67	2.40	2