

SAE Flange Plugs

STANDARD PRESSURE : CODE 61

SIZE	O-RING GROOVE PART NO.	FLAT FACE PART NO.	C	E	F	MIN O	MAX O	WT
1/2"	13041-08	13042-08	0.63	0.27	1.19	1.000	1.005	0.07
3/4"	13041-12	13042-12	0.67	0.27	1.50	1.250	1.255	0.11
1"	13041-16	13042-16	0.67	0.32	1.75	1.560	1.565	0.18
1 1/4"	13041-20	13042-20	0.67	0.32	2.00	1.750	1.755	0.24
1 1/2"	13041-24	13042-24	0.75	0.32	2.37	2.115	2.125	0.35
2"	13041-32	13042-32	0.75	0.38	2.81	2.490	2.500	0.59
2 1/2" ¹	13041-40	13042-40	1.58	0.38	3.31	2.995	3.005	1.98
3" ²	13041-48	13042-48	1.77	0.38	4.00	3.615	3.625	2.86

HIGH PRESSURE : CODE 62

SIZE	O-RING GROOVE PART NO.	FLAT FACE PART NO.	C	E	F	MIN O	MAX O	WT
1/2"	16041-08	16042-08	0.71	0.31	1.25	1.000	1.005	0.09
3/4"	16041-12	16042-12	0.59	0.35	1.63	1.250	1.255	0.18
1"	16041-16	16042-16	0.63	0.38	1.87	1.560	1.565	0.26
1 1/4"	16041-20	16042-20	0.63	0.41	2.13	1.750	1.755	0.37
1 1/2"	16041-24	16042-24	0.75	0.50	2.50	2.115	2.125	0.66
2"	16041-32	16042-32	1.18	0.50	3.13	2.490	2.500	1.03

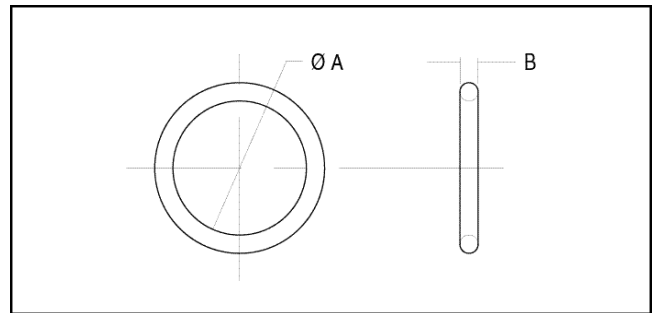
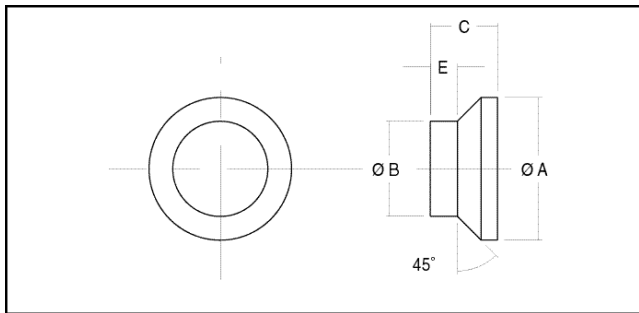

Weld Pipe Plugs for Schedules 40 & 80

PIPE SIZE	PART NO.	A	B	C	E
3/4"	10042-12	1.050	0.688	0.53	0.19
1"	10042-16	1.315	0.877	0.62	0.25
1 1/4"	10042-20	1.660	1.194	0.75	0.38
1 1/2"	10042-24	1.900	1.414	0.75	0.38
2"	10042-32	2.375	1.856	0.81	0.38

¹ 2500 PSI max.
² 2000 PSI max.

O-Rings — SAE

FLANGE SIZE	PART NO.	DASH SIZE	± .005 A	± .004 B
1/2"	OR12	-210	0.734	0.139
3/4"	OR34	-214	0.984	0.139
1"	OR1	-219	1.296	0.139
1 1/4"	OR114	-222	1.484	0.139
1 1/2"	OR112	-225	1.859	0.139
2"	OR2	-228	2.234	0.139
2 1/2"	OR212	-232	2.734	0.139
3"	OR3	-237	3.359	0.139
3 1/2"	OR312	-241	3.859	0.139
4"	OR4	-245	4.359	0.139
5"	OR5	-253	5.359	0.139